

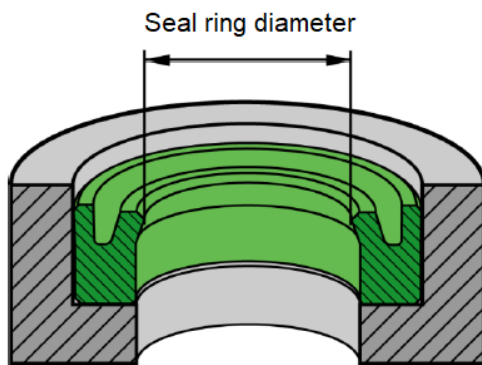

Profilometer



Inner diameter grooved ring

Description:

- Optical measuring method for quantifying geometric features
 - Diameter
 - Distances
 - Angles
- Inspection of form and position tolerances
- Non-destructive
- Contactless

Technical Data:

Measuring range:	300 x 300	mm
Resolution:	0,001	mm

Available Test Methods:

- Quality assurance: Used to determine the inner and outer diameters of sealing rings and seal carriers
- Wear tests: Regular measurement of the inner diameter in tests